



40 amp 28 volt sensorless motor drivers

Small, compact, no programming or set up required. Up to 99% efficiency, no inductors required for slotless or ironless motors.

Table of Contents

Digital closed and open loop drives with speed, direction, brake inputs and tach output.....	2
CV3 braking module.....	5
Speed pot with leads.....	6
Technical notes and application information.....	7

Ultra high efficiency miniature sensorless drive with 37kHz pwm frequency, designed for use with stand alone, digital or analog operation. The drive has no minimum inductance and will operate slotless or ironless brushless motors without the need for bulky, cumbersome inductors. The drives can be operated in stand alone mode with a speed pot or with an 0-5v analog input or a 5v pwm input from a microcontroller or microprocessor. The motor is turned off for an PW input between 0 and .5 volts. Once power supply, motor and speed pot (if used) are connected, the motor can be operated without the need for any adjustments, set up or programming. Connector termination is not needed. If reversible operation is required a SPDT switch can be added between DR and P- or a 5v signal may be used. Speed input can be accomplished with a 0-5v analog input (less than 1mA) or a 8kHz to 100kHz 5v square wave with variable duty cycle. For monitoring the speed or closing the speed loop externally the tach output TC can be used. TC outputs a 5v square wave with a frequency equals to 3 pulses per revolution for a 2 pole motor, 6 for a 4 pole etc. The direction is controlled by 0v (reverse) or 5v (forward) to the DR input. For analog operation the TC output can be connected to a one shot, filtered and a DC voltage proportional to the rpm will result. To brake the motor use a switch between P+ and BK, or an external 5v signal. The brake function is accomplished by shorting the motor windings and does not require an external braking resistor. The drive weighs 6.5 oz. The operating temperature range is -55°C to 105°C. Drive life may be reduced at baseplate temperatures above 60°C. Drives can be custom programmed for optimum closed loop performance for a specific motor and application. The motor can be turned on and off using the EN terminal or by reducing the speed input below .5v.

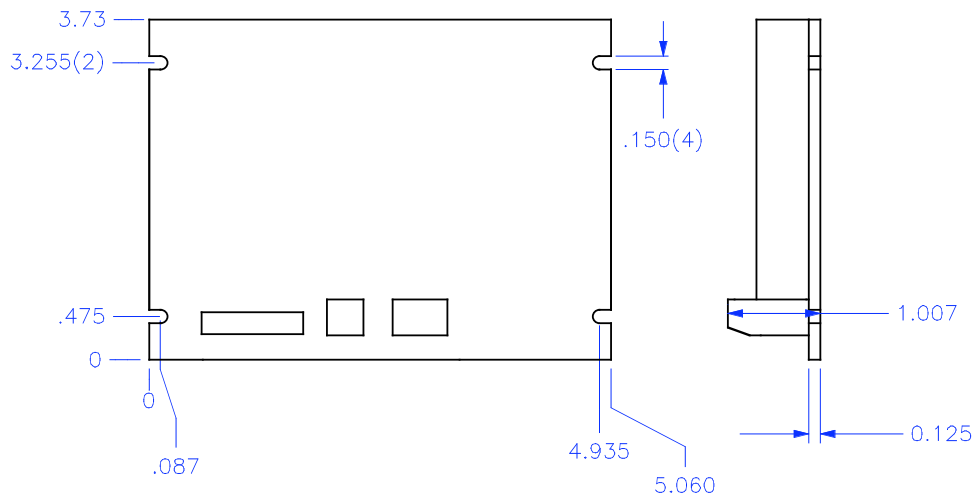

Terminal block positions (motor lead hook up for Koford motors).

- P+=connect to one side of pot (5.0v) (red)
- PW=connect to pot wiper (center terminal) (purple)
- P-=connect to other side of pot (ground) (black)
- EN=unconnected or 5v to run, 0v to turn motor off
- DR=leave unconnected for forward direction, hook to P- for reverse
- BK=unconnected or 0v=off, 5v=on

- TC=tach/encoder output 3 pulses per revolution per magnet pole pair (1000 hz=20,000 rpm, 2 pole motor)
- =Connect to black (-) lead of power supply
- + =Connect to red (+) lead of power supply
- A=blue motor wire
- B=white motor wire
- C=brown motor wire

Ordering information:

please send the order to mail@koford.com

Part number:

S28V40A-8 closed loop speed control 5v=5k rpm (2 pole), 2.5k rpm (4 pole) with direction, tach and brake

S28V40A-13 closed loop speed control 5v=10k rpm (2 pole), 5k rpm (4 pole) with direction, tach and brake

S28V40A-1 closed loop speed control 5v=20k rpm (2 pole), 10k rpm (4 pole) with direction, tach and brake

S28V40A-2 closed loop speed control 5v=40k rpm (2 pole), 20k rpm (4 pole) with direction, tach and brake

S28V40A-3 closed loop speed control 5v=80k rpm (2 pole), 40k rpm (4 pole) with direction, tach and brake

S28V40A-5 duty cycle control, up to 100,000 rpm. 5v=100% duty cycle, direction, tach and brake, suggested for motor with for winding resistances, 12V less than .3Ω, 24V less than .6Ω

P1 Optional speed pot with knob and leads

Stand alone operation with speed pot, motor direction can be reversed by switching any two leads with each other.

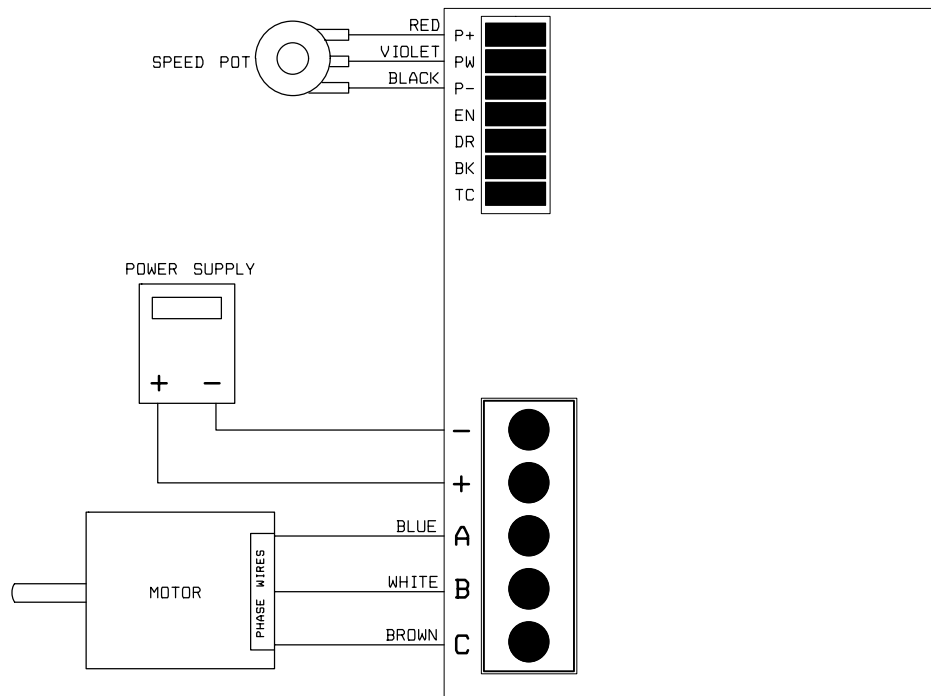

Stand alone operation with speed pot and brake

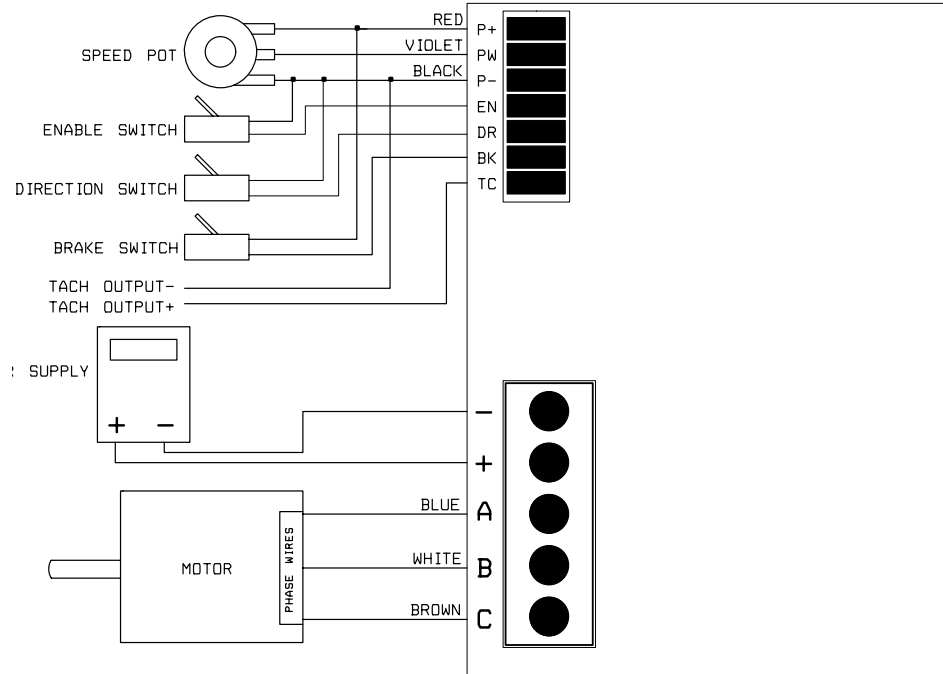

External control

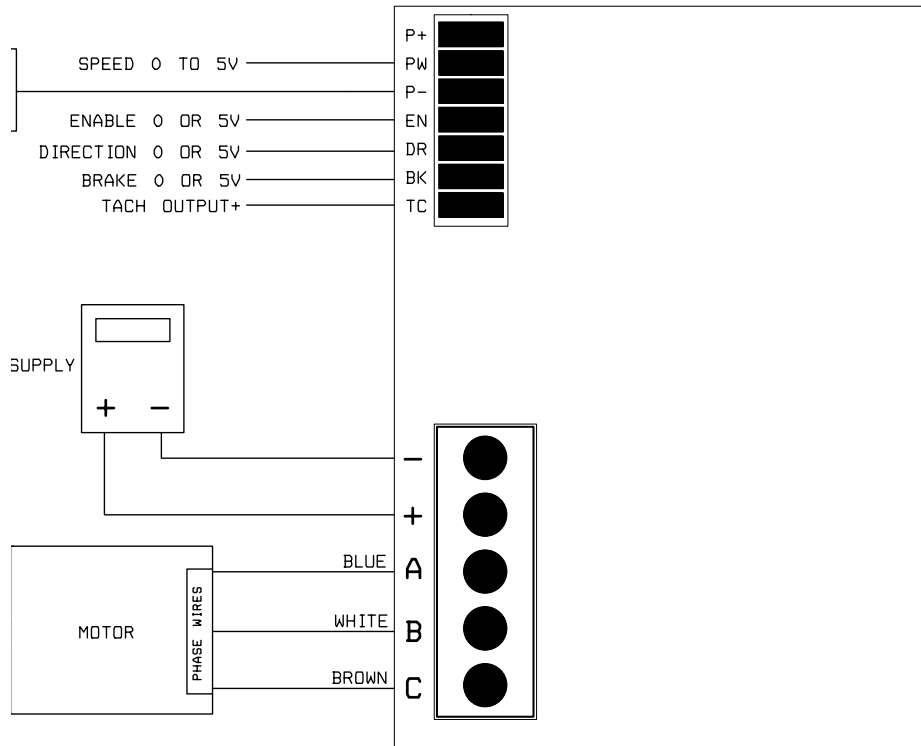

The CV-3 braking module is for use when a drive with braking function is connected to a power supply. If a battery supplies the power, the module is not needed. The module is needed on a system with a power supply because otherwise the regenerated energy would cause an overvoltage condition in the power supply. That would cause power supply shut off and/or power supply damage. The module contains Schottky diodes to prevent current backflow and also a TVS to absorb the transient braking energy. The TVS is needed because otherwise the braking energy would cause an overvoltage in the drive damaging it.

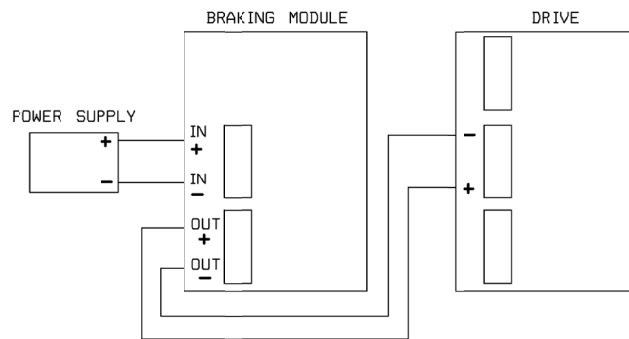
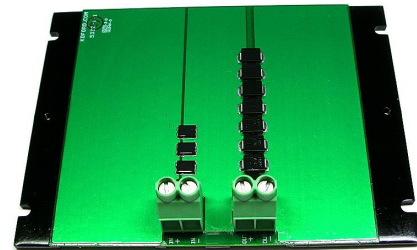
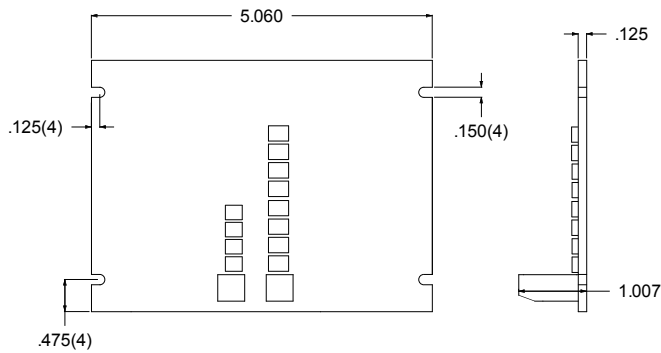

SPEED POT AND KNOB

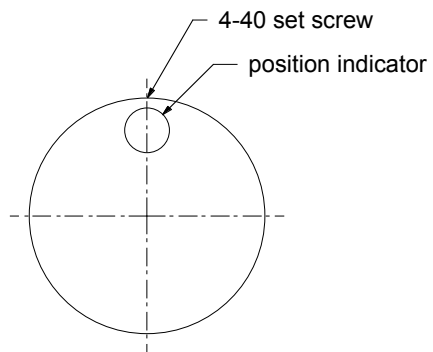
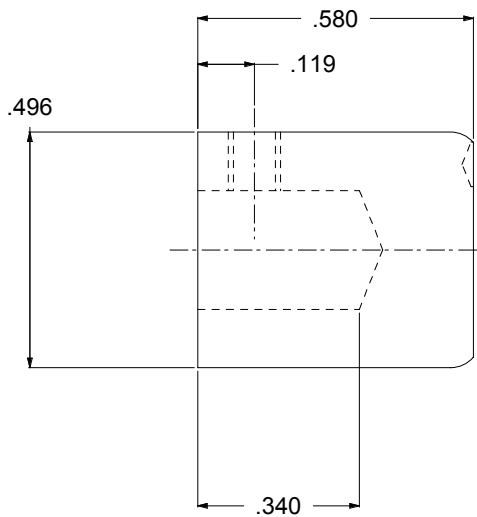
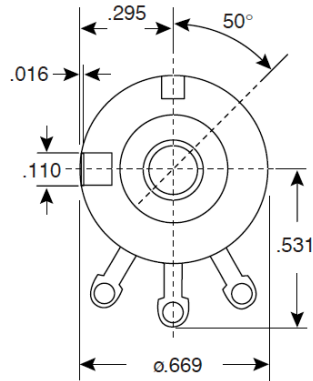
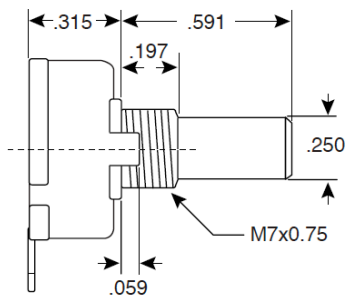
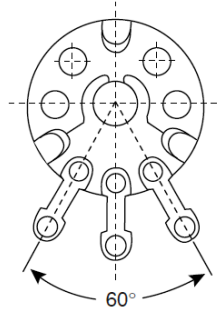
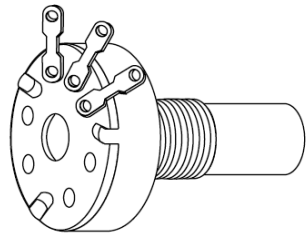

Leads are 3.440" long stranded 22 gauge with TFE insulation.

Notes

1. If 5v are applied to the speed input and the motor speed is 20k rpm with a 2 pole motor, then with a 4 pole motor the speed will be 10,000 rpm, an 8 pole motor 5,000 rpm, a 16 pole motor 2,500 rpm etc.
2. Any externally powered inputs such as speed or brake must be turned off when drive power is turned off or drive damage may result.
3. Sensorless drives work best with slotless or ironless brushless motors. Most slotted motors will work reasonably well but a few will not.
4. The maximum speed depends on the characteristic of the motor, however Koford 2 pole motors will run well up to 120,000 rpm with the -5 version of the drive and 4 pole motors up to 60,000 rpm. Slotted motors will have a lower maximum speed which must be determined by testing.
5. When using a microcontroller to control the drive a 5 volts output should be used. If the pwm frequency is greater than 8Khz no filtering is required, for lower frequencies an RC filter should be used to produce a DC output.
6. The current limiting of the drive limits the current delivered to the motor to slightly above 40 amps, this means that the current at the power supply will reach a maximum of slightly above 40 amps with the speed turned to maximum, if the speed is reduced then the current at the power supply will be proportionately reduced so as to maintain the current at the motor at a maximum of 30 amps. The current at the power supply is different then the power delivered to the motor unless the duty cycle (speed) is set to 100%. For example if the duty cycle (speed) is set to 50% then at a motor current of 40 amps the power supply current will be 20 amps.
7. The drive should preferably be mounted to an aluminum chassis or frame, or a aluminum heat sink. Drive heat rise is greatest at high currents, low duty cycles and continuous operation. If the application is 100% duty cycle, with normal indoor ambient temperature, the current is low compared to the rated current, or if the application is intermittent with on times for example of 1 minute and off times of at least 1 minute, then a heat sink will probably not be necessary. For high ambients forced air cooling directed at the board can help. For long term reliability, it is recommended that sufficient cooling be provided to prevent the hottest spot on the board from exceeding 100C. This can be checked with a portable infrared thermometer
8. Sensorless motors cannot operate near zero speed as they need back emf to determine the correct point of commutation. There is also a minimum duty cycle required for proper commutation which limits the speed range. If the motor has no load then the speed range may only be 40% to 100% due to energy stored in the motors inductance (depending on the motor). With a slight load the speed range increases to 20% to 100%. At 50% of rated current the range is 15% to 100%. These values are approximate and depend on motor inductance, efficiency and input voltage. If a wider speed range is required then contact the factory.
9. If the direction input is changed while the motor is running the drive will stop the motor and then restart in the opposite direction after a brief pause.
10. The motor rpm can be read using a multimeter with a frequency or tach function. $1000 \text{ hz} = 20,000 \text{ rpm}$ with a 2 pole motor, 10,000 rpm with a 4 pole motor, 5,000 rpm with a 8 pole motor etc. The tach function on a scope can also be used or the output can be connected to a datalogger or interfaced with a 5 volt input capable micro, or a buffer can be connected to the drive to bring the voltage down to 3.3v or lower if required.