

20 amp 24 volt hall sensor motor drivers

Small, compact, no programming or set up required. Up to 99% efficiency, no inductors required for slotless or ironless motors.

Table of Contents

H24V20A-5 Digital closed and open loop drives with speed, direction and tach output.....	2
H24V20A-3 Digital closed loop drives with speed, direction and brake inputs and tach output.....	4
H24V20A-4 Digital closed loop drive with speed, direction and motor temperature inputs, and tach output.....	6
CV2 braking module.....	7
Speed pot with leads.....	8
Technical notes and application information.....	9

Ultra high efficiency miniature hall sensor drive with 37khz pwm frequency, designed for use with stand alone, or external input operation. The drive has no minimum inductance and will operate slotless or ironless brushless motors without the need for bulky, cumbersome inductors. For stand alone operation the speed pot with wires and knob should be ordered. In this configuration once power supply, motor and speed pot are connected the motor can be operated without the need for any adjustments, set up or programming. If reversible operation is required a SPDT switch can be added between Dir and P-. For external speed control the unit will interface with a customers microcontroller. The microcontroller should be 5v or be a 3.3v with 5v interface capabilities. Speed input can be accomplished with a 0-5v analog input (less than 1mA) or a 1 khz to 100k Hz square wave with variable duty cycle. The direction is controlled by 0v (counterclockwise) or 5v (clockwise) to the DIR input. Directions is as viewed from the motor mounting surface. If the motor speed is turned to zero the motor will coast. If braking is required use the drive which follows on page 5 in this catalog. Motor rpm can be measured if needed by connecting a multimeter or scope between HA and H-. For a 2 pole motor 100 hz=6,000 rpm, for a 4 pole motor 100hz= 3,000 rpm. The drive weighs 1.9 oz. The operating temperature range is -55 to 105C, however operating at an ambient below 60C will increase drive life.

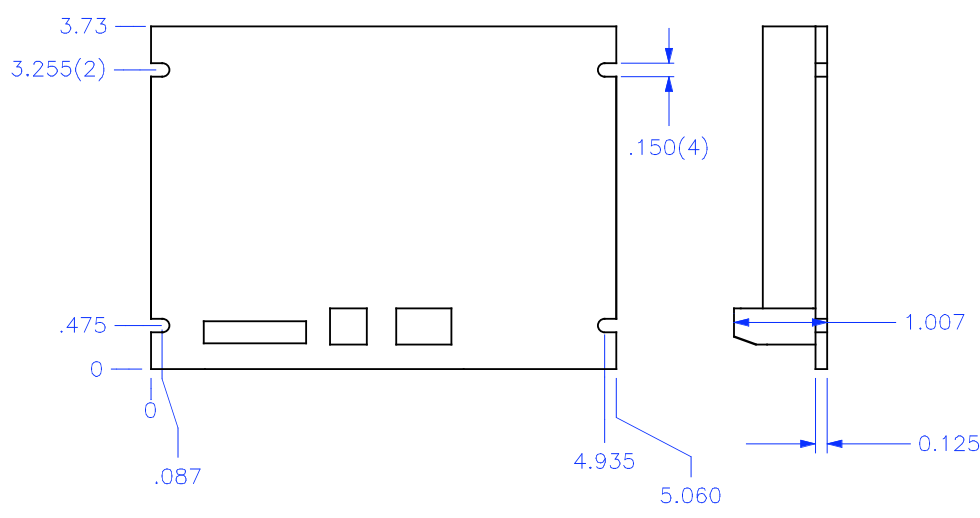

Terminal block positions (motor lead hook up for Koford motors)
 DIR=leave unconnected for forward direction, connect to P- for reverse
 P+=connect to one side of pot (5.0v)
 PW=connect to pot wiper (center terminal)
 P-=connect to other side of pot (ground)
 H-=black motor wire (hall ground)
 H+=red motor wire (hall power)
 HA=yellow motor wire

HB=orange motor wire
 HC=green motor wire
 -=Connect to black (-) lead of power supply
 +=Connect to red (+) lead of power supply
 B=white motor wire
 A=blue motor wire
 C=brown motor wire
 BRK=no connection
 BG=ground reference for speed input

Ordering information:

mail@koford.com

Part number

H24V20A-5 Open loop drive

H24V20A-9 Closed loop drive 5k rpm 2p, 2.5k rpm 4p, 1.25k rpm 8p

H24V20A-10 Closed loop drive 10k rpm 2p, 5k rpm 4p, 2.5k 8p

H24V20A-11 Closed loop drive 20k rpm 2p, 10k rpm 4p, 5k 8p

H24V20A-12 Closed loop drive 40k rpm 2p, 20k rpm 4p, 10k 8p

H24V20A-13 Closed loop drive 80k rpm 2p, 40k rpm 4p, 20k 8p

P1 Speed pot, with knob and leads (info on pg. 8)

Basic configuration

Rotation for Koford motors is clockwise as viewed from the motor mounting surface. If only rotation in the counterclockwise direction is needed, connect a jumper between DIR and P-.

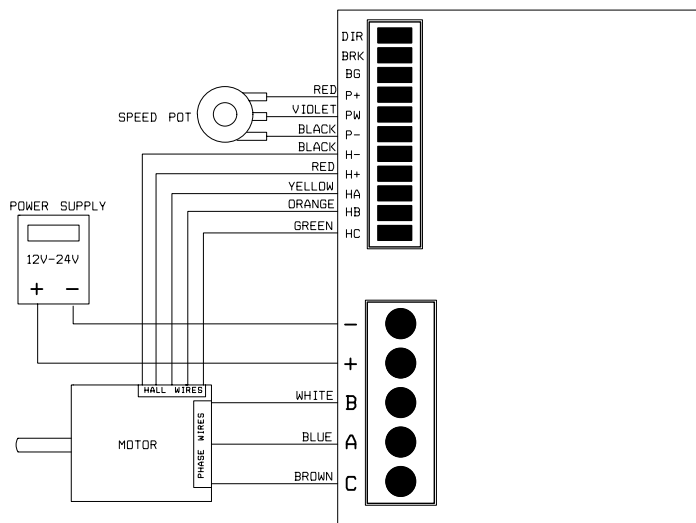

Stand alone operation with direction

Direction switch not needed if only rotation in one direction is needed, use Basic configuration shown above in that case.

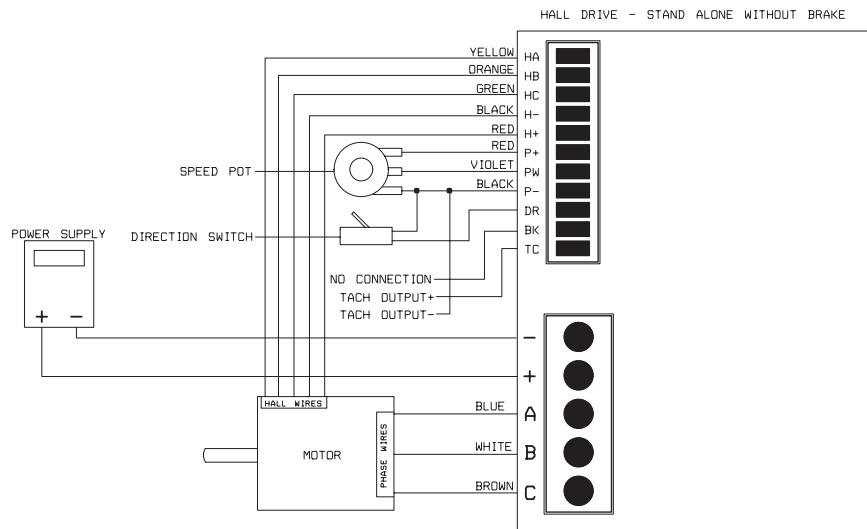

External control

Rotation for Koford motors is clockwise as viewed from motor mounting surface, counterclockwise if 0v is applied to DIR, and clockwise if 5v is applied.

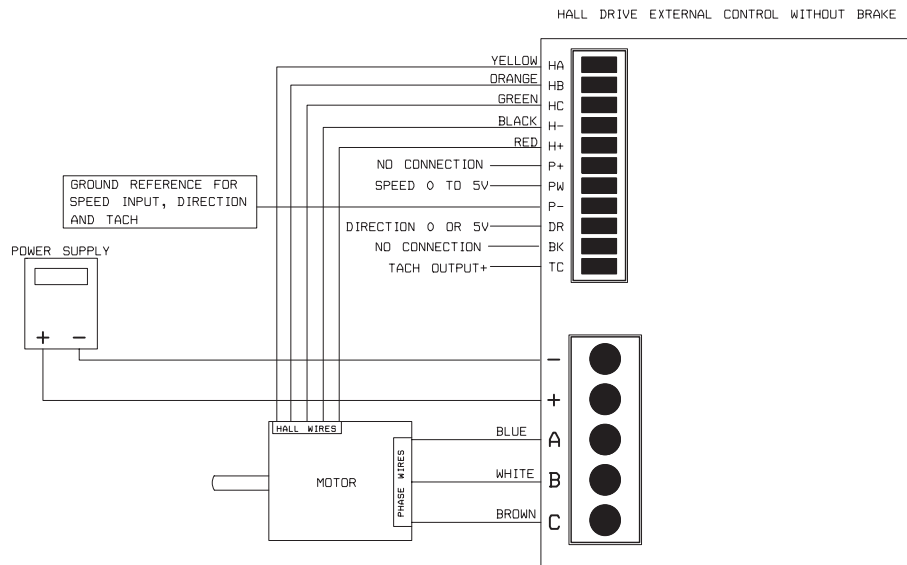

Ultra high efficiency miniature hall sensor drive with 37k pwm frequency, designed for use with stand alone, or external input operation. The drive has no minimum inductance and will operate slotless or ironless brushless motors without the need for bulky, cumbersome inductors. The drive can be used with or without the brake function. For stand alone operation the speed pot with wires and knob should be ordered. In this configuration once power supply, motor and speed pot are connected the motor can be operated without the need for any adjustments, set up or programing. If reversible operation is required a SPDT switch can be added between Dir and P-. For external speed control the unit will interface with a customers microcontroller. The microcontroller should be 5v or be a 3.3v with 5v interface capabilities. Speed input can be accomplished with a 0-5v analog input (less then 1mA) or a 1 khz to 100k Hz square wave with variable duty cycle. The direction is controlled by 0v (counterclockwise) or 5v (clockwise) to the DIR input. Direction is as viewed from the mounting surface. Brake is off if the BRK is left disconnected. To apply brake connect BRK to P+ with a swich, or use an external 5v signal connected between BRK and BG. No extra components are required for battery power as the regenerated energy will recharge the batteries, when operating using a power supply an overvoltage shutoff of the power supply may result if the braking energy is large. In this case a CV-3 will be required between the power supply and the drive. This unit absorbs the braking energy and isolates it from the power supply. Motor rpm can be measured if needed by connecting a multimeter or scope between HA and H-. For a 2 pole motor 100 hz=6,000 rpm, for a 4 pole motor 100hz= 3,000 rpm. The drive weighs 1.9 oz. The operating temperature range is -55 to 105C, however operating at an ambient below 60C will increase drive life.

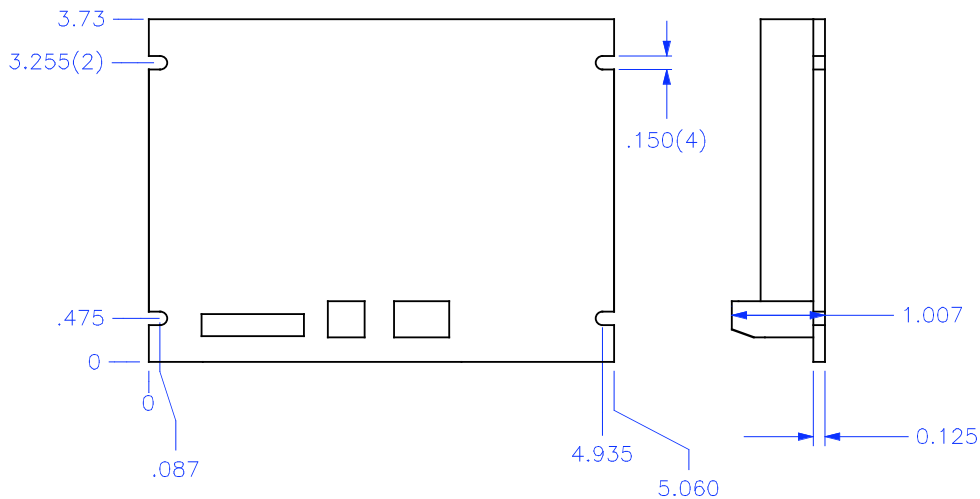

- Terminal block positions (motor lead hook up for Koford motors)
- DIR=leave unconnected for forward direction, connect to P- for reverse
- P+=connect to one side of pot (5.0v)
- PW=connect to pot wiper (center terminal)
- P-=connect to other side of pot (ground)
- H-=black motor wire (hall ground)
- H+=red motor wire (hall power)
- HA=yellow motor wire

- HB=orange motor wire
- HC=green motor wire
- =Connect to black (-) lead of power supply
- =+Connect to red (+) lead of power supply
- B=white motor wire
- A=blue motor wire
- C=brown motor wire
- BRK=brake off 0v or if left disconnected, 5v= on)
- BG=ground reference for brake and speed input

Ordering information:

mail@koford.com

Part number

H24V20A-3 Closed loop drive with brake 5k rpm 2p, 2.5k rpm 4p, 1.25k rpm 8p

H24V20A-4 Closed loop drive with brake 10k rpm 2p, 5k rpm 4p, 2.5k 8p

H24V20A-6 Closed loop drive with brake 20k rpm 2p, 10k rpm 4p, 5k 8p

H24V20A-7 Closed loop drive with brake 50k rpm 2p, 25k rpm 4p, 12.5k 8p

H24V20A-8 Closed loop drive with brake 100k rpm 2p, 50k rpm 4p, 25k 8p

P1 Speed pot, with knob and leads (info on pg. 8)

CV-2 braking module (info on page 7)

Stand alone operation with direction and brake

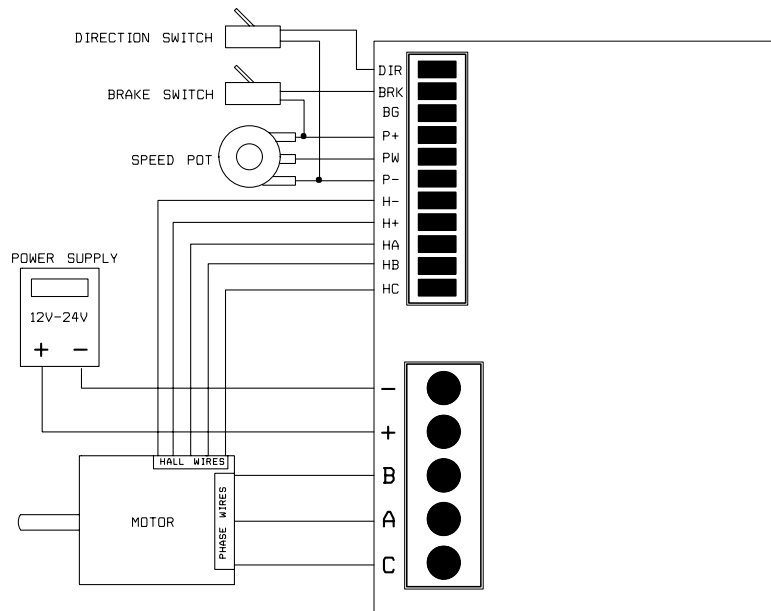

External control

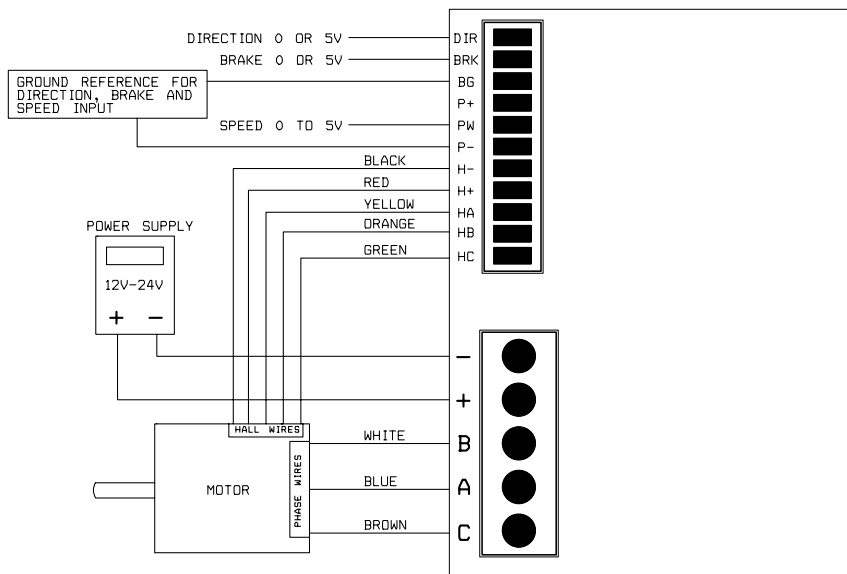

The CV-2 braking module is for use when a drive with braking function is connected to a power supply. If a battery supplies the power, the module is not needed. The module is needed on a system with a power supply because otherwise the regenerated energy would cause an overvoltage condition in the power supply. That would cause power supply shut off and/or power supply damage. The module contains Schottky diodes to prevent current backflow and also a TVS to absorb the transient braking energy. The TVS is needed because otherwise the braking energy would cause an overvoltage in the drive damaging it.

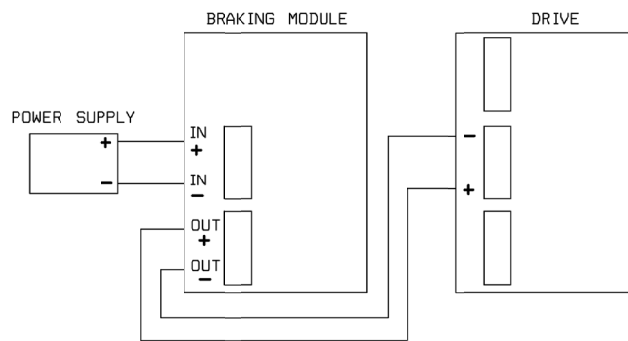
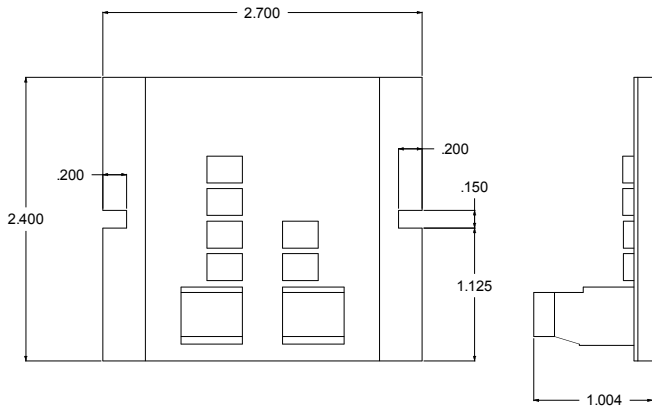

SPEED POT AND KNOB

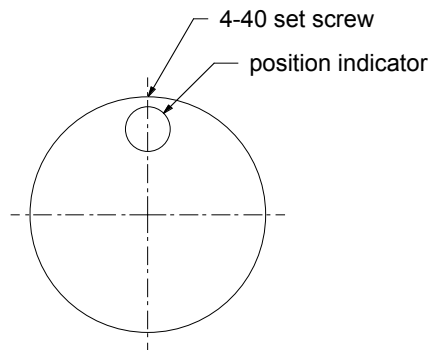
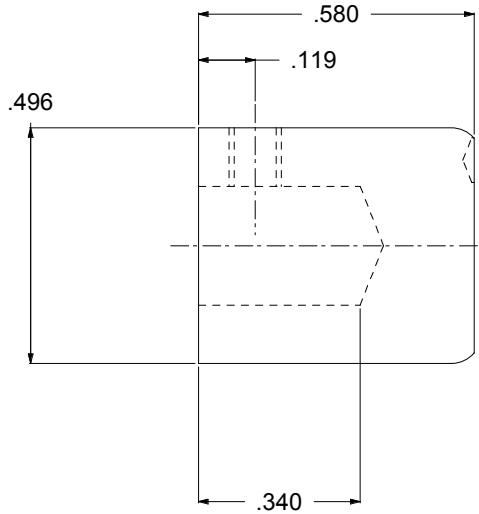
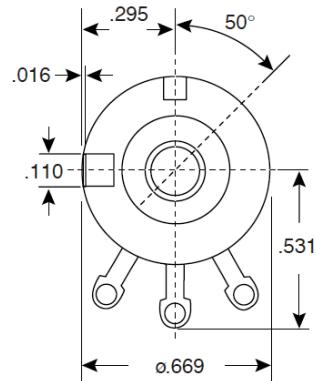
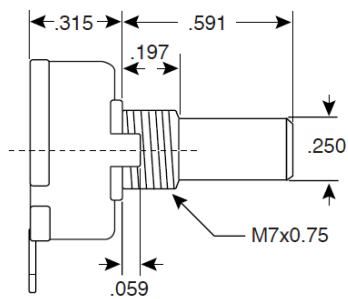
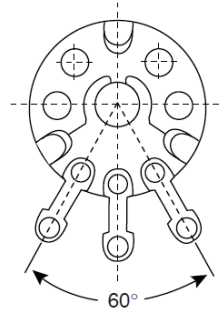
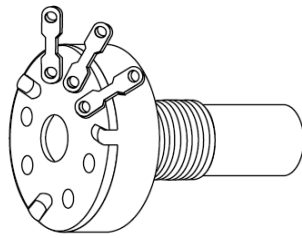

Leads are 3.440" long stranded 22 gauge with TFE insulation.

Notes

1. When using a microcontroller to operate the drive a 5 volts output should be used and the pwm frequency should be 1Khz or more, Up to 8kHz a RC filter should be used between the micro and the drive to filter the signal.
2. The current limiting of the drive limits the current delivered to the motor to slightly above 20 amps, this means that the current at the power supply will reach a maximum of slightly above 20 amps with the speed turned to maximum, if the speed is reduced then the maximum current at the power supply will be proportionately reduced so as to maintain the current at the motor at a maximum of 20 amps. For example if the motor speed is reduced by 50% then the maximum power supply current will be reduced by about 50% also but the motor will put out the same torque.,
3. The drive should preferable be mounted to an aluminum chassis or frame, or a aluminum heat sink. Drive heat rise is greatest at high currents, low duty cycles and continuous operation. If the application is 100% duty cycle, with normal indoor ambient temperature, or if the current is low compared to the rated current, or if the application is intermittent with on times for example of 1 minute and off times of at least 1 minute, then mounting the drive to aluminum will probably not be necessary. For high ambients forced air cooling directed at the board can help. For long term reliability, it is recommended that sufficient cooling be provided to prevent the hottest spot on the board from exceeding 100C. This can be checked with a portable infrared thermometer
4. Direction change on digital drive models is allowed only when the speed command is set to zero. For applications requiring rapid reversing the speed should be set to zero for long enough to allow the motor to come nearly or completely to a stop before changing the direction command. Setting the speed to zero while the motor is spinning will brake the motor. The direction on analog drives can be changed even when the speed command is set to a non zero value but this is not recommended to prevent drive/motor damage.
5. When connecting other brands of motors make sure that the motor selected uses 120° halls. Hook up halls and sensors in the sequence indicated on the motor information. If the motor runs in the opposite direction desired either use the direction input to change direction or switch Phase A with Phase B and Hall HC with Hall HA. If the motor information uses different designations for the hall leads or if the motor is hooked up but does not run or pulls high current even when unloaded try switching the hall leads with each other until you find the correct combination.
6. Although the drive will function up to 200,000 rpm with a 2 pole motor, hall motors work poorly at such speeds. Above 100,000 rpm with a 2 pole motor or 50,000 rpm with a 4 pole motor the efficiency of a hall motor starts to drop off compared to running the same motor with a sensorless drive. Above 100,000 rpm with a 2 pole motor and 50,000 rpm with a 4 pole motor the loss in efficiency is excessive and hall motors are not recommended. This is due to limitations of the halls themselves, in part due to the timing being mechanically fixed rather than changing with speed and load as with a sensorless motor and in part due to the switching delay of hall sensors. The performance of hall motors at high speed can be improved by advancing the timing of the motor as long as the motor runs in one direction only. Hall motors are necessary for operation down to zero speed or for positioning applications.